

A + A STOPPING COMPOUND



DESCRIPTION

A + A STOPPING COMPOUND is a plaster-based compound used for flushing joints of plaster board. It can also be used as putty touch up the fibrous plaster board that produces a smooth fine finished using steel trowel.



TECHNICAL DATA

COLOUR	White
BINDER	Gypsum
FILLER	Calcium Carbonate Powder
WATER RATIO DEMAND	Powder 2 : 1 Water
PACKAGING	20 kg ±
SETTING TIME	25 minutes
COVERAGE	360 ft ² of Plasterboard per 20kg

PACKING & STORAGE

- **A + A Stopping Compound** packed in 20KG± bags.
- **A + A Stopping Compound** must be stored in a dry place with pallet.
- **A + A Stopping Compound** has a shelf life of 9 months from date of manufacture.
- **A + A Stopping Compound** storage in an unsuitable environment can shorten the lifespan of this product.

APPLICATION INSTRUCTION

Step1

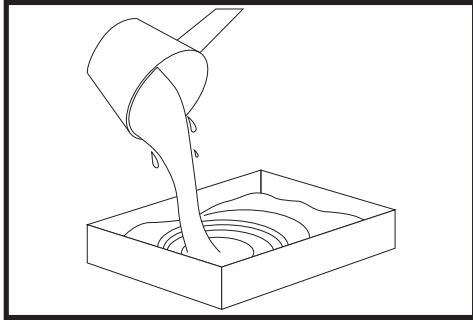

Pour clear water into the tray.

Step2



Add A + A stopping compound to clear water at a ratio of 2 parts of plaster to 1 part water. Allow to soak for approximately 2-3 minutes before mixing.

Step3

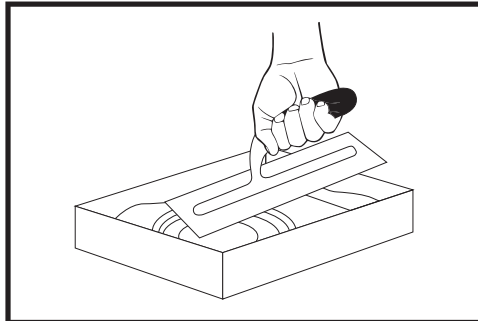

Mix thoroughly until a smooth consistency compound is achieved. Avoid mixture with residue of older batches.

Step4

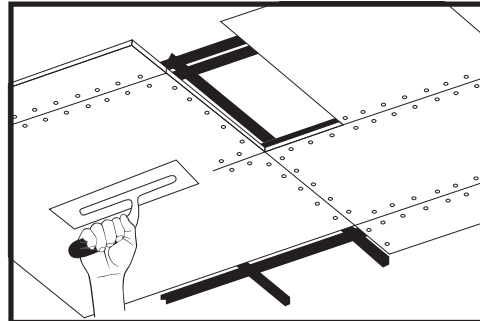

Apply A + A stopping compound from tray. (use within 30 minutes after mixing)

HEALTH & SAFETY

A + A STOPPING COMPOUND is not hazardous based on the major compound. However, we do recommend workers shall use safety equipment where necessary. In case of eye contact, immediately hold eyelids apart and flush eye continuously with running water. Get medical aid immediately when necessary.

Note: The information of applications and suggestions for use is based on practical experience. As due to various site conditions and unable to control the applications, therefore no responsibility can be accepted by us for any loss and damaged as this data sheet is for general guidance only.

Note: ASG reserve the rights to revise any data without prior notice.

ASG[®]

Lot 8600, Batu11, Jalan Segenting,
Telok Panglima Garang, 42500 Selangor.

Tel: 603- 3122 8505/8515
Fax: 603- 3122 9505
HP: 6012- 3315160

Email: info@asgplaster.com
<https://www.asgplaster.com>

All Right Reserved by ASG Group